



HANDLES

MANIGLIONI



 *M*aniglioni

 *t*ubular handles

 *t*iradores

*I*l maniglione tubolare è senz'altro la soluzione più pratica ed elegante da abbinare alla porta in vetro temperato. Gli esclusivi sistemi di fissaggio dei maniglioni, semplici, ma di estrema sicurezza, garantiscono un montaggio a prova di vibrazioni, come pure delle flessioni inevitabilmente trasmesse nel normale utilizzo.

Oltre all'accuratezza nella curvatura e alla particolare attenzione ai dettagli di finitura, i severi test di trazione ai quali sono continuamente sottoposti i maniglioni, condotti secondo la normativa UNI EN 10002/1-92, garantiscono una resistenza media a uno sforzo di spinta superiore ai 1100 Kg.

I maniglioni in alluminio sono prodotti da tubi estrusi in lega speciale di alluminio successivamente anodizzati o verniciati con polvere a base di poliestere al 100%. Ciò consente una durata nel tempo del colore e un'elevata resistenza all'usura come pure ai raggi ultravioletti e alle condizioni atmosferiche più impegnative, come dimostra l'assoluta immutabilità in seguito a 1000 ore di immersione in nebbia salina.

Quelli in acciaio inossidabile sono prodotti da tubo elettrosaldato AISI 304 L di alta qualità, accuratamente lucidati o satinati uno per uno.

I diametri disponibili sono 22 e 33 mm e per ogni materiale è possibile un'ampia scelta di modelli.

Per maniglioni di forme o misure non rappresentate nel presente catalogo, si prega di indirizzare la richiesta specifica al nostro UFFICIO VENDITE.

*T*his tubular push-bar is certainly the most practical and elegant solution for tempered glass doors. The exclusive mounting systems, simple but extremely secure, provide an assembly that withstands vibrations and the flexure inevitably transmitted by normal use.

In addition to the accurate curvatures and special attention to finish, the severe tensile testing to which these push-bars are constantly subjected in accordance with UNI EN 10002/1-92 standards ensure they can withstand an average pushing stress of more than 1100 kg.

The aluminum push-bars are produced from extruded pipe of special aluminum alloy, anodized or powder-painted with an all-polyester coating. This ensures long colour duration and resistance to wear, as well as UV rays and the toughest weather conditions, as demonstrated by perfect resistance to 1000 hours of immersion in saline fog.

The stainless-steel push-bars are produced from high-quality electrowelded AISI 304 L pipe, carefully polished or brushed one by one. The push-bars are available in diameters of 22 and 33 mm and a broad choice of models in each material.

For any other shape of pull-handles not included in this catalogue, please contact our SALES OFFICE.

*E*l tirador tubular es sin duda la solución más práctica y elegante de combinar a la puerta de vidrio templado.

El exclusivo sistema de fijación de los tiradores garantiza un montaje a prueba de vibraciones, como también de la flexión inevitable transmitida por el normal uso.

Además de la cuidada curvatura y la particular atención de los detalles de acabado, los severos "test" de tracción a los cuales son sometidos los tiradores, efectuados según la normativa UNI EN 10002/1-92, garantizan una resistencia media a un esfuerzo de empuje superior a los 1100Kg.

Los tiradores de aluminio son productos de tubo extrusionado en aleación especial de aluminio ya sean anodizados o pintados con polvo a base de poliestere al 100%. Esto consiente una conservación en el tiempo del color y una elevada resistencia al desgaste y también a los rayos ultravioletas y a las condiciones atmosféricas más negativas, como demuestra la absoluta inmutabilidad después de 1000 horas de inmersión en la niebla salina.

Aquellos en acero inoxidable están producidos de tubo electro-soldado AISI 304 L de alta calidad, cuidadosamente abrillantado o satinado uno por uno.

El diámetro disponible es de 22 y 33 mm y en cada material es posible una amplia gama de modelos.

Para tiradores de forma y medida no representadas en el presente catálogo, rogamos dirigir la consulta específica a nuestra OFICINA DE VENTAS.

022 *f*initure - *f*inishes - *A*cabados

611

Alluminio anodizzato naturale
Silver anodized aluminium
Aluminio anodizado natural

632

Alluminio anodizzato oro brillante
Polished gold anodized aluminium
Aluminio anodizado oro brillante

RAL 9010

Alluminio laccato bianco
White powder coated aluminium
Aluminio lacado blanco

810

Acciaio inox satinato
Satin stainless steel
Acero inoxidable satinado

812

Acciaio inox lucido
Polished stainless steel
Acero inoxidable brillante



Articolo Item Artículo	19119
Interasse Axes distance Entre ejes	x : 250 x : 350
Finiture Finishes Acabados	611 - 632 RAL 9010 810 - 812

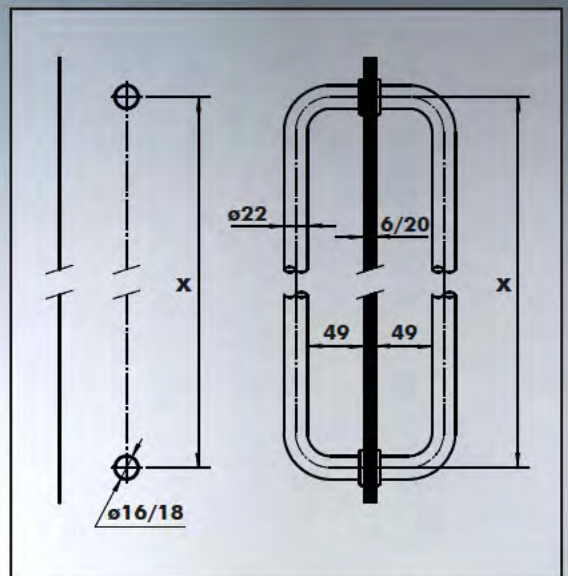

0.0

Articolo Item Artículo	19120
Interasse Axes distance Entre ejes	x: 250 x: 350
Finiture Finishes Acabados	611 - 632 RAL 9010 810 - 812

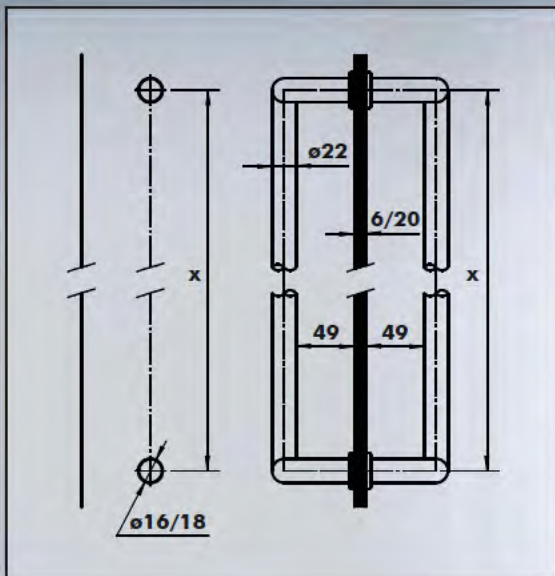

00





Articolo Item Artículo	19121
Interasse Axes distance Entre ejes	x : 250 x : 300
Finiture Finishes Acabados	611 - 632 RAL 9010 810 - 812

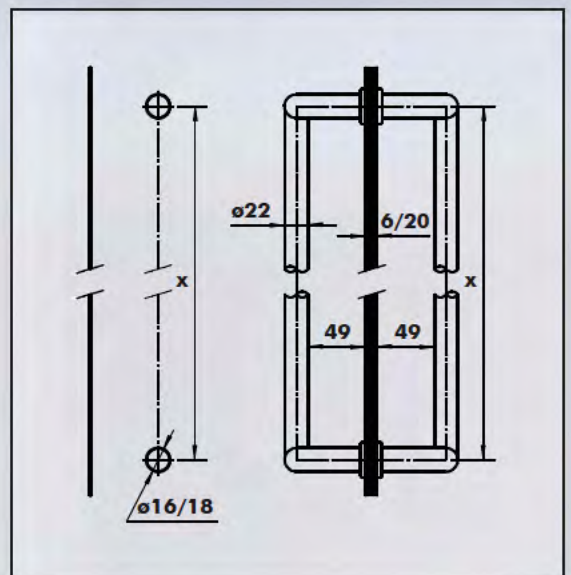

00

Ø33 *f*initure - *f*inishes - *A*cabados

611

Alluminio anodizzato naturale
Silver anodized aluminium
Aluminio anodizado natural

632

Alluminio anodizzato oro brillante
Polished gold anodized aluminium
Aluminio anodizado oro brillante

RAL 9010

Alluminio laccato bianco
White powder coated aluminium
Aluminio lacado blanco

810

Acciaio inox satinato
Satin stainless steel
Acero inoxidable satinado

812

Acciaio inox lucido
Polished stainless steel
Acero inoxidable brillante



Articolo Item Artículo	19115
Interasse Axes distance Entre ejes	x : 220 x : 300 x : 360
Finiture Finishes Acabados	611 - 632 RAL 9010 810 - 812

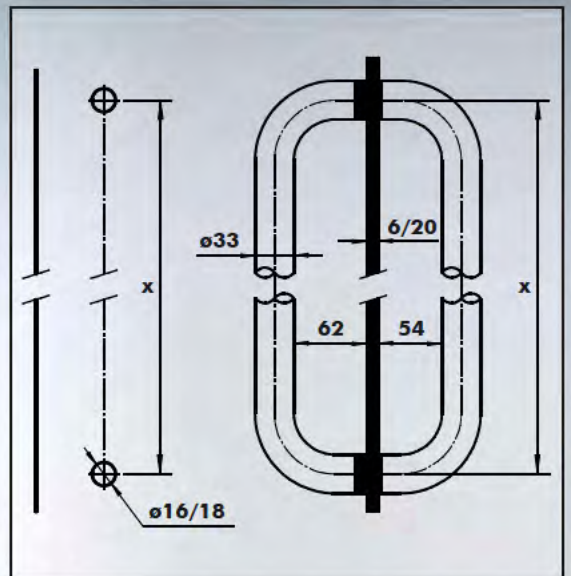

00



Articolo Item Artículo	19116
Interasse Axes distance Entre ejes	x : 300 x : 360
Finiture Finishes Acabados	611 - 632 RAL 9010 810 - 812

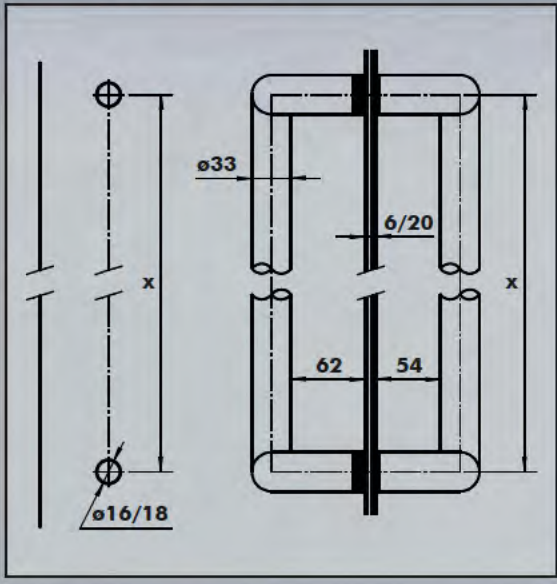

0.0



Articolo Item Artículo	19117
Interasse Axes distance Entre ejes	x : 250 x : 300
Finiture Finishes Acabados	611 - 632 RAL 9010 810 - 812

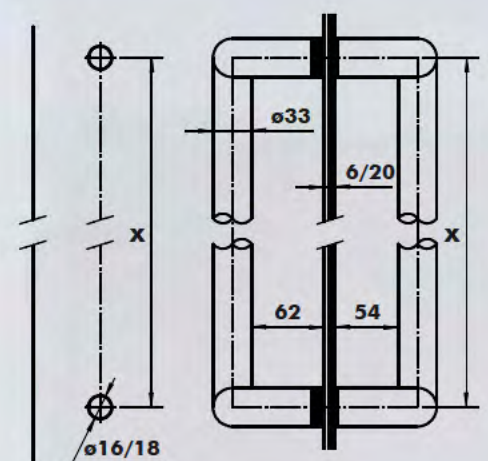

00



Articolo Item Artículo	19123
Interasse Axes distance Entre ejes	x: 250 x: 450
Dimensioni Dimensions Dimensiones	A: 400 A: 600
Finiture Finishes Acabados	611 - 632 RAL 9010 810 - 812

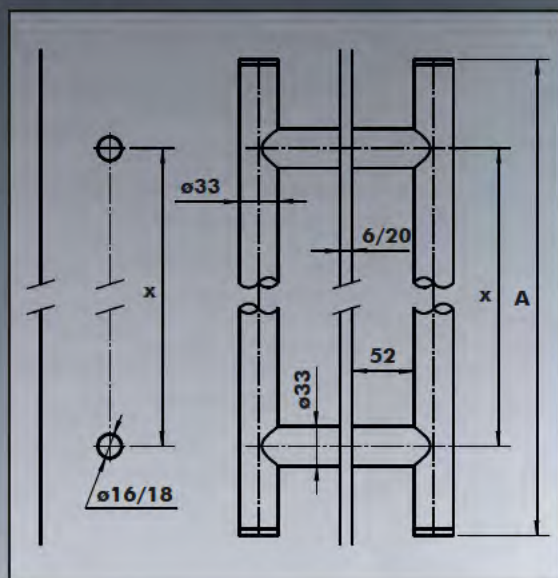

Disponibile anche in ø40
 Also available in ø40
 Disponible también en ø40

00

*A*ccessori di fissaggio maniglioni

*f*ixing accessories for tubular handles

*A*ccesorios de fijación para
tiradores tubulares





Accessori di fissaggio in inox
per coppie di maniglioni $\varnothing 22$

Stainless steel glass fixing
kit for double handles $\varnothing 22$

Accesorios de fijación en acero
inoxidable para juegos de tiradores $\varnothing 22$

$\varnothing 22$



Ø33



Accessori di fissaggio per
coppie di maniglioni Ø33

Glass fixing kit for double
handles Ø33

Accesorios de fijación para
juegos de tiradores Ø33



In caso di temperature inferiori a -10°C
si consiglia di utilizzare le ghiera in acciaio

In case of temperatures lower than -10°C we
suggest to use the stainless steel fixing kit

En caso de temperatura inferior a -10°C
se aconseja utilizar los anillos en acero



Art. 19122

Set di boccole di copertura

Cover rings pair

Juego de anillos de recubrimiento



www.sbyc.it



speedy getasa



TECHNOLOGICAL PRODUCTS
FOR GLASS ARCHITECTURE

SPEEDYBYCASMA Srl
Via 1° Maggio, 86 - 20013 Magenta (MI) - Italia
Tel. +39 02 97298418 +39 02 87188746 - Fax +39 02 97299006
info@sbyc.it - www.sbyc.it